



Right-of-Way Permit Provisions and Conditions

Pursuant to Wisconsin Statutes, this permit is granted to allow performance of the specific work described herein. The following general conditions, fee schedule, standard provisions and any included special provisions are hereby included and made part of this permit and shall govern:

1. **Indemnification.** The Applicant/Contractor agrees to indemnify and hold harmless the Permitting Authority (City of Neenah), its officers, employees and its agents, from any cost, claim, suit, liability and/or award which might come, be brought, or be assessed, because of the issuance or exercise of this permit, or because of any adverse effect upon any person or property which is attributed to the partially or entirely completed works of the Applicant/Contractor. Accomplishment of the permitted work, or any part thereof, by or on behalf of the Applicant/Contractor shall bind such Applicant/Contractor to abide by this permit and all its conditions and provisions.

In consideration of being permitted to make such excavation and occupy City street right-of-way, the Applicant/Contractor hereby agrees to:

- faithfully comply with the terms of this permit, including the Special Provisions;
- comply with all applicable statutes, ordinances, rules, and regulations of the State of Wisconsin and the City of Neenah;
- become qualified by the City of Neenah prior to starting work on this permit;
- indemnify, defend and hold the City of Neenah and its employees, officers and agents, and all private and governmental contractors and subcontractors with the City under CH.83 or 84, Stats., harmless from any and all claims, liability, loss, damage or expense incurred by the City of Neenah on account of any injury to or death of any person or any damage to property caused by or resulting from activity or work performed under this permit, whether caused by or resulting from activity or work performed under this permit, whether caused by or contributed to by the City of Neenah, its officials, agents or employees;
- at his own expense, investigate all such claims and demands, attend to their settlement or other disposition, defend all actions based thereon and pay all charges of attorneys and all other costs and expenses of any kind arising from any such liability, damage, loss, claims, demands and actions;
- purchase comprehensive public liability, contractual and property damage insurance, with the City of Neenah, its officers, employees, and agents as named additional insured for a period of three (3) years from the date of completion of work hereunder, in an amount not less than \$1,000,000 per claim occurrence from a company or companies authorized to do business in the State of Wisconsin and licensed by the Wisconsin Insurance Commissioner, said insurance shall be evidenced by a certificate of insurance showing the City of Neenah as a named additional insured and shall provide thirty (30) days written notice to the City upon cancellation or

material change in the policy with renewal certificates provided to the City for three (3) years from the date of completion of work hereunder.

2. Terms of Completion-Liquidated Damages. Should the Applicant/Contractor fail to complete the work by the established dates as set forth in this permit, he shall be charged the sum of \$_____ for each and every day including Sundays and holidays that the work remains incomplete. Said sums per day shall be considered as liquidated damages for the non-compliance of the work embraced in this permit within the times above specified for its completion, or within such further times as in accordance with the provisions of these specifications, shall be fixed or allowed for such performance or completion of this work.

In view of the difficulty of estimation of such damages, it is agreed upon, fixed, and determined by both parties hereto that the above liquidated damages are these that the City will suffer by reason of such default and are not considered a penalty. The periods of time for completion set forth above shall be extended in the amount equal to time lost due to causes which could not have been foreseen or which are beyond the control of the Applicant/Contractor, and which were not the result of his fault, negligence or deliberate act. Extensions of time for completion shall also be allowed for delays in the progress of the work caused by any act or omission on the part of the City or its employees, or by other contractors employed by the City or delay due to an act of the government or any other cause which in the opinion of the Director of Public Works entitles the Applicant/Contractor to an extension of time. Strikes and labor disputes shall be cause for an extension of time. Final cleanup is considered part of the contract and shall be completed before the contract time elapses.

3. Instructions to Applicant/Contractor

- A. All applications for new installations shall be accompanied by:
- a detailed, to scale engineering drawing showing all dimensions, all existing utilities, curbs, sidewalks, trees, hydrants, valves, driveways and other pertinent features;
 - the profile of line and grade of any proposed underground utility with dimensions so as to avoid conflicts with other existing underground utilities;
(Note: "Field design" and adjusting the line and grade of the proposed installation at the time of construction is not acceptable);
 - a photo rendering of the site of the proposed installation.
- B. The final permit excavation fee will be based on the actual "as built" size of the excavation. The fee will be adjusted accordingly.
- C. A copy of this approval, along with any plans and special provisions, shall be available on the job site.
- D. Upon completion of the work the Applicant/Contractor will file a written notice of completion of work with the Department of Public Works.
- E. For each job, the Applicant/Contractor shall provide at least 2 names, phone numbers, pager numbers, cell phone numbers, etc. for contact 24 hours per day, 7 days per week.

- F. This permit may be voided by the Department of Public Works if the work is not started within a reasonable length of time after the above stated starting date.
 - G. The Applicant/Contractor may forfeit liquidated damages to the City for failure to complete the work within the established terms of completion.
 - H. Time limits for construction, clean up and completion of initial patching shall be established as part of the permit process. Failure to complete all work and clean up of the area within the established time frame will result in assessment of liquidated damages. Liquidated damages shall be established by the Engineer based on scope of work, disruption of traffic, timelines of completion and any other factors that may apply.
4. The permitted facilities shall, if necessary, be altered at the expense of the Applicant/Contractor to permit alteration, improvement, or maintenance of the street as may hereafter be ordered. The entire cost of construction and maintaining the permitted facilities shall be the obligation of the Applicant/Contractor unless a contract for such costs has been executed.
5. Video Facilities. The granting of this permit to place certain cabinet facilities (“facilities”) in the public right-of-way is conditioned upon the Grantee obtaining all permits, licenses, franchises and permissions required under federal, state or local law prior to Grantee's commencement of the use of the facilities to provide any video programming or other programming services, as those terms are defined in 47 U.S.C. Section 522, as amended, to subscribers in the City. Further, Grantee agrees it will not use the facilities as part of a network occupying the public right-of-way for the provision to subscribers in the City of video programming or other programming service, as those terms are defined in 47 U.S.C. Section 522, as amended, unless Grantee provides the City Clerk 30 days prior written notice. Except for the granting of this permit under Chapter 14, Neenah Code of Ordinances, this action by the Director of Public Works shall not constitute nor be construed as a grant of any permit, license, franchise or permission otherwise required under federal, state or local law.
6. Workmanship
The Applicant/Contractor shall:
- A. not block access to public streets and private driveways;
 - B. have all temporary concrete and asphalt work within the right-of-way installed in an approved manner and in accordance with City of Neenah construction specifications;
 - C. complete all temporary restoration of the street, sidewalk, alley or terrace affected by this permit within twenty-four (24) hours of the completion of the excavation;
 - D. guarantee the work will be free from defects for thirty six (36) months following the date of completion;
 - E. restore all disturbed streets, alleys, sidewalks, terraces and other areas to their present condition or better, subject to the satisfaction of the Department of Public Works or its representative;

- F. perform any trenching, tunneling, or excavating in accordance with the requirements of OSHA and the Wisconsin Department of Commerce, and any applicable Federal, State and local regulations;
- G. save from damage any pipes, drains, or structures encountered and shall pay for the repair or any damage to such structures that may result from his operations;
- H. assume all of the responsibility to protect and re-establish all survey monuments and all the lot line stakes (property irons) in the area of the street in which he is working. The Applicant/Contractor shall not remove, bury or disturb any lot line stakes or property monuments he encounters in his work and shall be liable for the cost of replacing any stakes or monuments including the cost of a survey to relocate the lot line;
- I. acknowledge and agree that after twenty-four (24) hours written notice the City reserves the right to remedy any neglect on the part of the Applicant/Contractor as regards to the protection of the work and public; except in case of emergency when the owner shall have the right to remedy any neglect without due notice. In either case, the owner shall deduct the cost of such remedy from any money due or to become due the contractor.

7. Environmental Protection

- A. General. In conducting the work, Applicant/Contractor shall observe all laws and regulations with respect to environmental pollution and protection of the environment. The Applicant/Contractor shall comply with the requirements of any and all authorities having jurisdiction over the work.
- B. Protection of Waterways. The Applicant/Contractor shall not pollute any wetland, lake, river, stream or other watercourse by the dumping of any refuse, rubbish, debris or dredged material therein. The Applicant/Contractor shall be responsible for providing the temporary means and facilities necessary to transport, divert and detain all flows, including storm flows and flows created by construction operations, so as to prevent silting of waterways and flooding damage to property.
- C. Protection of Sewers. The Applicant/Contractor shall take adequate measures to prevent the impairment of existing sewers and sewerage systems; and prevent construction materials, earth and debris from entering sewers and sewerage facilities.
- D. Protection of Potable Water Systems. The Applicant/Contractor shall take adequate measures to prevent contamination and the impairment of existing potable water facilities and piping, both public and private.
- E. Disposal of Surplus Excavated Materials and Wastes. Surplus excavated material and other waste material resulting from the work shall be legally disposed of by the Applicant/Contractor. The Applicant/Contractor shall make his own arrangements and pay all costs in connection with the disposal of such materials.
- F. Air and Noise Pollution. The Applicant/Contractor shall conduct his operations and provide those means necessary to minimize air and noise pollution resulting from the work. No burning of material or trash will be permitted on the site. All roads and other

areas, when necessary, shall be periodically watered or given an approved dust-prevention treatment.

- G. Protection of Property. The Applicant/Contractor shall employ such means and methods to adequately protect all property against damage. In the event of damage to property, Applicant/Contractor shall at his own expense immediately restore the property to a condition at least equal to its original condition as the engineer may determine.
- H. Protection of Trees and Plants. It is the responsibility of the Applicant/ Contractor to protect all trees, shrubs, lawns, etc., not specifically designated for removal by the engineer.

The Applicant/Contractor shall tunnel, bore or "rat hole" under large trees to prevent excessive damage to the tree's roots. The length of bore shall vary, but in general, shall extend three (3) feet on each side beyond the diameter of the trunk (i.e. a 3 foot diameter tree will require a 9 foot bore).

Trees shall be protected as follows:

- To prevent excessive root damage, all roots exposed in the trenches shall be carefully "root pruned" as directed.
 - All trees in the immediate area of construction shall be wrapped with wood snow fence to protect the trunk's bark from damage resulting from accidentally being hit by equipment. Wrapping shall be done as directed.
 - Where shown on the plan and/or where directed, the Applicant/Contractor shall use a small rubber-tired backhoe to excavate in tight areas next to trees.
 - The Applicant/Contractor shall use extreme care and adjust his operation such that damage to limbs is minimized. Under no circumstances shall limbs be haphazardly broken off. All damaged limbs shall be trimmed and pruned by a professional tree nurseryman. All costs associated with this work shall be the responsibility of the Applicant/Contractor.
 - It is almost impossible to place a value on some of these trees. The Applicant/Contractor shall protect them from damage. Damage to these trees will be charged back to the Applicant/Contractor and it could conceivably be very expensive. The Applicant/Contractor is advised to exercise extreme care and take this into consideration in his bid.
 - Any small bushes in the area of the work may be dug up and transplanted after the trench is backfilled.
- I. Erosion Control. The Applicant/Contractor shall construct and maintain Best Management Practice (BMP) erosion and sediment control measures to control sediment from leaving the site in accordance with the City of Neenah erosion control ordinance, the most recent DNR Administrative Code (NR150 series) and all other local, state, and federal requirements. Where shown on the Improvement Plans, and as directed by the engineer, the Applicant/Contractor shall erect and maintain these erosion control measures. The Applicant/Contractor shall maintain these BMP's until the site has been stabilized or another contractor or the City takes over maintenance.

The Applicant/Contractor shall install and maintain all BMP's as directed.

Any additional erosion control measures deemed necessary by the Engineer shall be constructed, installed and maintained by the Applicant/Contractor at his expense.

Erosion from the job site shall be controlled by the Applicant/Contractor at all times. Stockpiles of erodible materials shall be adequately contained. Job site runoff water which contains suspended materials shall be adequately filtered before discharge to the storm sewer. Trench dewatering shall not be discharged to the sanitary sewer. Trench dewatering shall be properly filtered and sediment trapped before being discharged off site or to the storm sewer. The erosion control techniques described in Chapter 2.8.0 EROSION CONTROL of the Standard Specifications for Sewer and Water Construction in Wisconsin, the Wisconsin DNR Construction Site Best Management Practice Handbook and the City of Neenah Erosion Control Ordinance shall be employed.

- J. Dust Abatement. The Applicant/Contractor is required to control dust especially when working on or near established residential streets. Dust abatement shall be considered incidental and provided as directed by the Engineer. Should the Applicant/Contractor not adequately provide for dust abatement, as determined by the Engineer, the Engineer may order the work to be done by others and any incurred costs shall be charged to the Applicant/Contractor.
- K. Construction Noise Abatement. In order to abate objectionable noise to the extent feasible, motorized construction equipment shall not be operated between the hours of 8:00 p.m. and 7:00 a.m. without the prior written approval of the Engineer. Each item of motorized construction equipment shall be equipped with a muffler constructed according to the equipment manufacturer's specifications or a system for equivalent noise reducing capability. Mufflers and exhaust systems shall be maintained in good operating condition, free from leaks and holes.
- L. Tracking of mud, dirt and debris from the construction area shall not be permitted. The Applicant/Contractor shall sweep and clean any debris from the streets on a daily, regular basis and as frequently as necessary depending upon the conditions. Failure to maintain and clean the streets will result in the City doing this work and billing the Applicant/Contractor at the established rates.
- M. When required by the Director of Public Works, the Applicant/Contractor shall submit for approval an erosion control plan. This plan must be implemented.
- N. The Applicant/Contractor is responsible for the excavation, testing, hauling and proper disposal of all contaminated soil. He shall also be completely responsible for completing all necessary and required permits, forms, approval and other "paper work".

8. Traffic Control and Barricades

- A. Protection of Public. The Applicant/Contractor shall furnish and maintain sufficient barricades, lights, flags, warning signs, and all other protective measures, devices, and methods necessary to protect the public from the hazards created by his operations. The Engineer or his representative may order more barricades, lights, flags, warning

signs, and other protective measure devices and methods as he deems necessary for the protection of the public.

- B. No open cutting for a street crossing will be permitted where the pavement is too narrow to maintain one-way traffic at all times, unless the Director of Public Works has granted permission for a detour.

When one-way traffic or a detour is permitted, the Applicant/Contractor shall provide all necessary signs, flagmen and lights required according to the latest edition of the "Manual on Uniform Traffic Control Devices" (MUTCD). When a detour is allowed, the Police Department, Fire Department, Ambulance Service, Valley Transit, Neenah Joint Schools and local newspapers shall be notified by the Applicant/Contractor in advance of the work being started.

- C. When a detour is requested, the Applicant/Contractor shall provide the Traffic Engineer a five (5) working day notice prior to commencement of a detour and be completely responsible for installing and maintaining the correct and required traffic control as set forth in the most recent edition of the MUTCD.
- D. Three days prior to performing any maintenance work that will result in full or partial lane closures, the utility or Applicant/Contractor shall request the engineering department grant permission to close traffic lanes. Lane closures on primary arterial and secondary arterial street may be restricted to off peak traffic hours. (Example, closing traffic lanes at the intersection of Commercial Street and Wisconsin Avenue will not be permitted during morning and afternoon peak traffic periods of 6:30 a.m. to 8:30 a.m. or 3:30 p.m. to 5:30 p.m.).
- E. At all times the Applicant/Contractor shall keep the place where such excavation is made, properly guarded by day and lighted by night in accordance with the specifications as set forth in the most recent edition of the MUTCD.
- F. The cost to establish and maintain all traffic control shall be the responsibility of the Applicant/Contractor. All traffic control plans shall be submitted to the City Traffic Engineer for review. All traffic control shall conform with the most recent edition of the MUTCD.
- G. On major projects, when ordered by the City, the Applicant/Contractor shall give a minimum of 3 days advance notice to all affected property owners and motorists.

9. General Conditions

- A. Pavement damaged beyond the limits of the initial patch (i.e. undermining from trench collapse or water leak, heaved pavement due to water leak, cracked concrete or asphalt) will be resawed, evaluated and billed on a case-by-case basis.
- B. Contractors working under Public Works/Engineering contracts or direction will not be charged a permit fee, street repair fee, or street degradation fee.
- C. Coordination of utility patches and street excavations with the City's street reconstruction program may result in major reduction or elimination of permit fees.

- D. All excavated material shall become property of the Applicant/Contractor and shall be hauled away. The trench shall be backfilled with lime stone screenings and thoroughly compacted in layers. The pavement removed for a street excavation shall be replaced as per the City of Neenah specifications.
- E. "Flowable fill" slurry is recommended for backfill especially in small excavations and those excavations where the presence of other pipes and utilities make it difficult to achieve proper compaction of the backfill material.
- F. All fiber optic, cable T.V., or other telecommunications cable placed in City right-of-way shall be encased in conduit.

10. Design Criteria - Cabinets and Pedestals

- A. The Applicant/Contractor shall notify all of the abutting property owners at the requested location and the property owners across the street from the proposed installation. Vegetative screening may be required.
- B. There shall be a 4-foot horizontal clear distance between the curb-side face of the cabinet and the back edge of the curb.
- C. There shall be a 1-foot horizontal clear distance between the cabinet and the near edge of a sidewalk. There shall be a 2-foot horizontal clear distance between the cabinet and the near edge of a trail. If there is no existing sidewalk or trail, the City's Official Sidewalk and Trails Map or subdivision plat shall be used to determine future sidewalk/trail locations.
- D. There shall be a 6-foot horizontal clearance between the edge of the concrete cabinet base and the near edge of any storm sewer mains/laterals, sanitary sewer mains/laterals and water mains/services. This clearance may be increased if the main is deeper than typical depth.
- E. There shall be a 2-foot horizontal clearance between the edge of the concrete cabinet pad and any gas main or underground electric lines.
- F. The horizontal clearance between the concrete cabinet base and the trunk of any terrace tree shall be the greater of either 6 feet or the tree drip line.
- G. There shall be a 4-foot horizontal clearance between the concrete cabinet base and any street sign post, traffic signal, street light pole or any other utility pole.
- H. At street intersections, cabinets shall be placed outside of the vision clearance corner as defined by AASHTO (attached).
- I. At driveways, cabinets shall be placed outside of a 15-foot vision clearance triangle extended to the back-of-curb line (attached).
- J. Cabinets placed on private property shall not be placed within the 10-foot vision clearance area (attached).

- K. Cabinets shall not be located where they will conflict with future street widening/rebuilding projects.
- L. Cabinets shall not be located where they will conflict with future City utility projects.
- M. The City will consider installation of underground vaults in lieu of the aboveground cabinets. These will be reviewed on a case-by-case basis.

GENERAL NOTES

SAW CUT, DRILL, AND LIFT OUT EXISTING CONCRETE PAVEMENT WITHIN THE BOUNDARIES OF CONCRETE REPAIR AREAS. THE CONTRACTOR MAY MAKE ADDITIONAL SAW CUTS INSIDE THE REPAIR LIMITS TO REDUCE WEIGHT AND SIZE OF CONCRETE PIECES. ADDITIONAL SAW CUTS ARE NOT PAID FOR BY THE DEPARTMENT.

PROVIDE 6-FOOT MINIMUM DISTANCE FROM BOUNDARIES OF CONCRETE REPAIR AREAS TO ADJACENT TRANSVERSE JOINT OR CRACK.

THE LENGTH OF THE REPAIRS MAY VARY FROM THE DIMENSIONS SHOWN IF THE EXISTING CONCRETE PAVEMENT IS NONDOWELED AND THE PAVEMENT IS TO BE OVERLAID AFTER REPAIRING.

① DOWEL BARS MIGHT NOT EXIST.

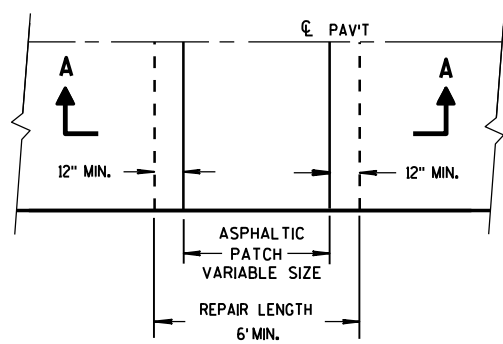

PLAN VIEW

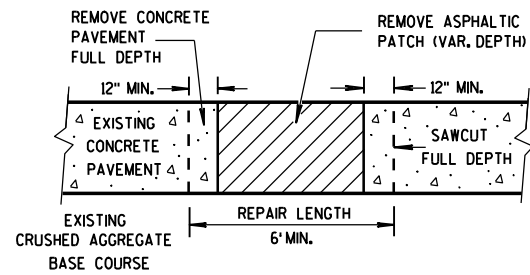

**SECTION A-A
HMA PATCH REMOVAL**

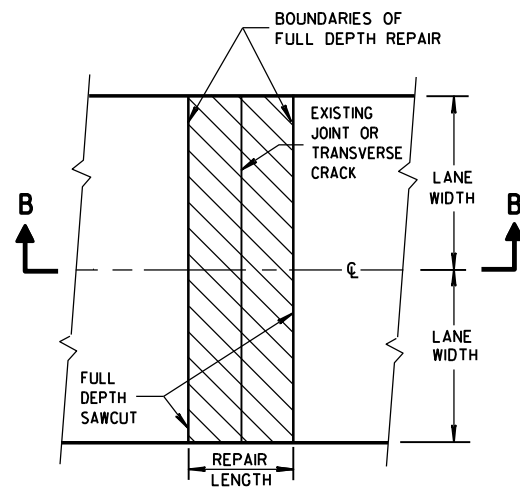

**PLAN VIEW
(DOUBLE LANE REPAIR)**

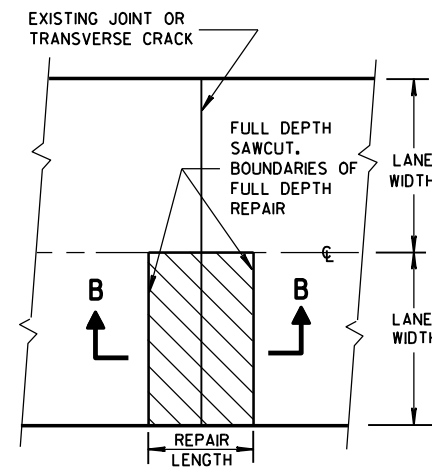

**PLAN VIEW
(SINGLE LANE REPAIR)**

FULL DEPTH CONCRETE PAVEMENT REMOVAL

(SEE NOTE)

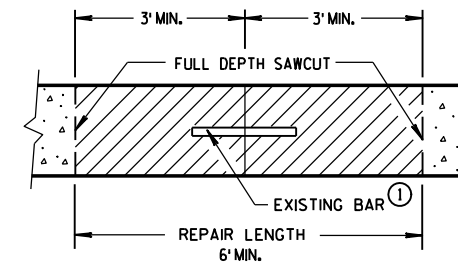

**SECTION B-B
CONCRETE REMOVAL**

6

6

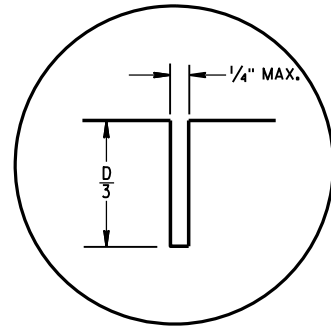

C1

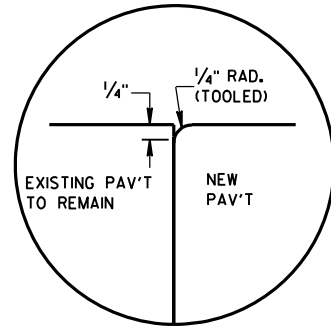

C2

TRANSVERSE JOINTS

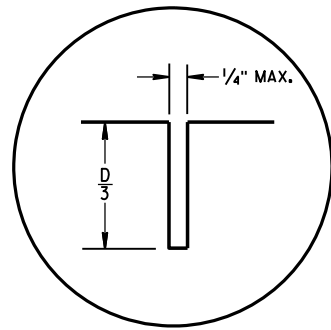

L1

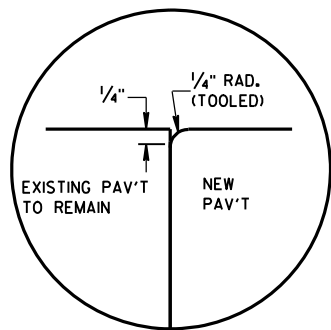

L2

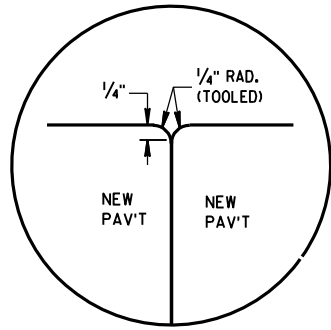

L3

LONGITUDINAL JOINTS

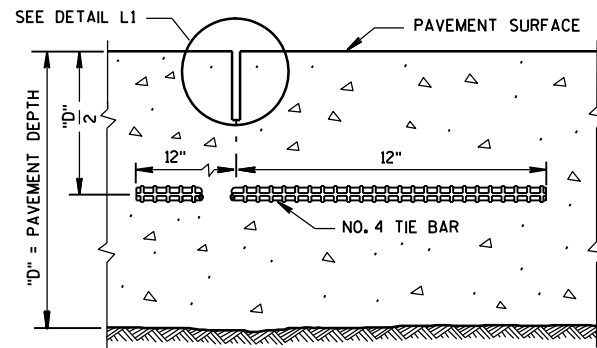

**SECTION C-C
SAWED LONGITUDINAL JOINT**

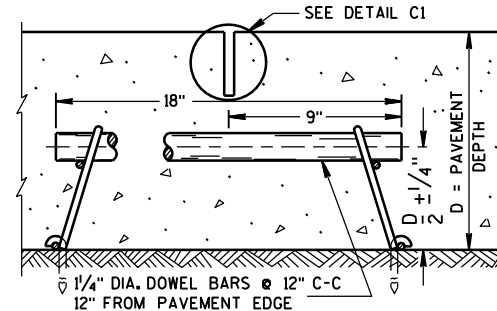

**SECTION F-F
CONTRACTION JOINT**

GENERAL NOTES

INSTALL DOWEL BARS PARALLEL TO THE PAVEMENT CENTERLINE AND PAVEMENT SURFACE.

CONCRETE PAVEMENT REPAIRS OF EXISTING NONDOWELED CONCRETE PAVEMENTS DO NOT NEED TO BE DOWELED.

DO NOT SEAL OR FILL JOINTS.

ANCHOR DOWEL BARS AND TIE BARS INTO DRILLED HOLES WITH AN EPOXY.

PROVIDE A MINIMUM DISTANCE OF 24 INCHES FROM AN EXISTING TRANSVERSE JOINT OR THE EDGE OF REPLACEMENT TO THE CENTER OF THE TIE BAR NEAREST THAT JOINT OR EDGE.

① APPLY A THIN UNIFORM COATING OF SURFACE TREATMENT TO THE FREE END OF DOWEL BARS TO PREVENT BONDING.

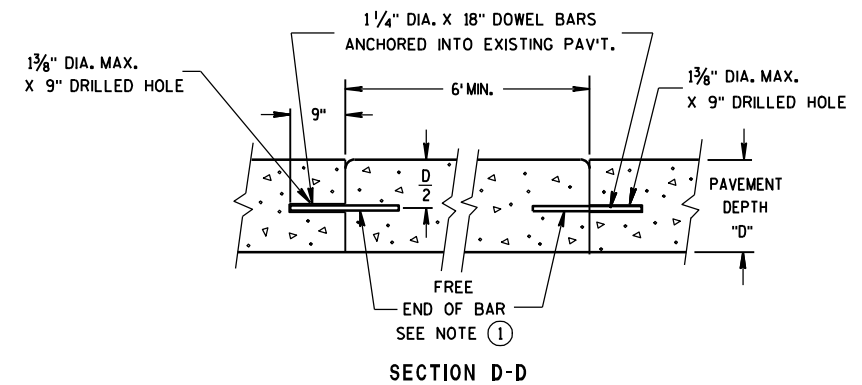

SECTION D-D

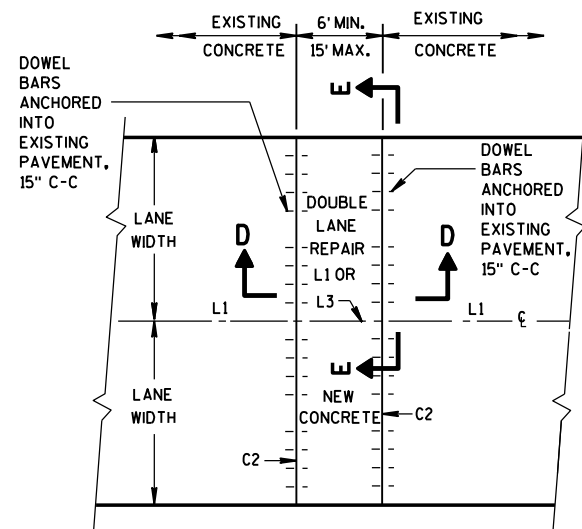

PLAN VIEW

MULTI-LANE CONCRETE PAVEMENT REPAIR

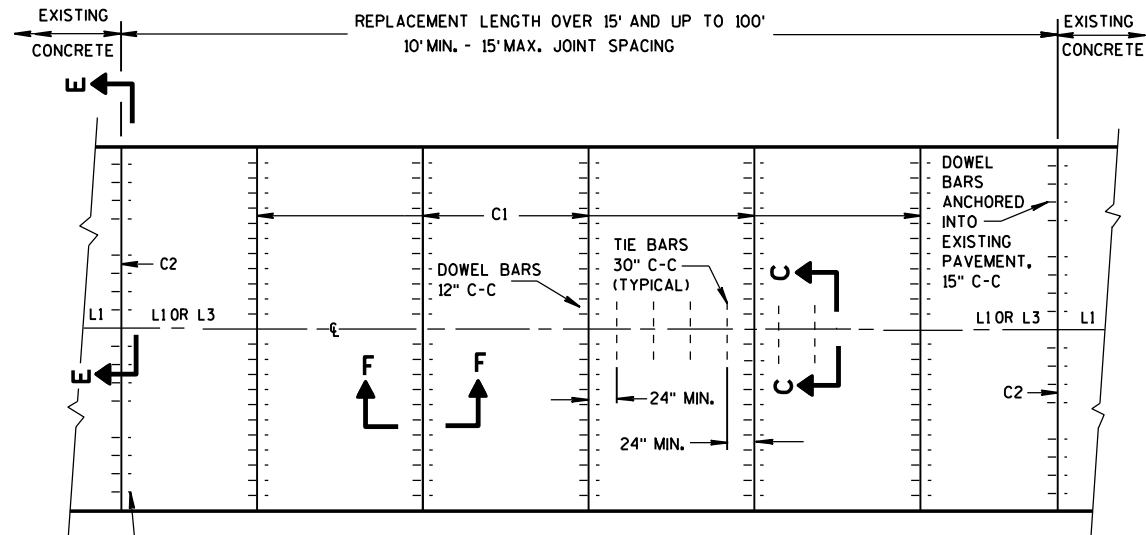

PLAN VIEW

MULTI-LANE CONCRETE PAVEMENT REPLACEMENT

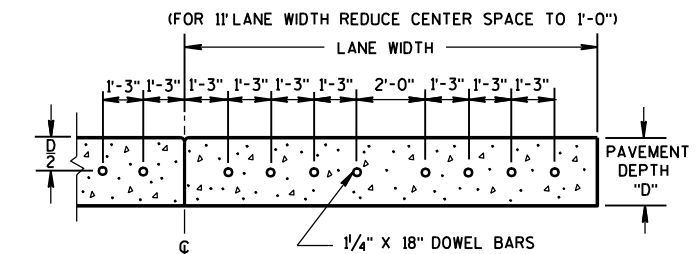

SECTION E-E

SPACING OF DOWEL BARS ANCHORED INTO EXISTING PAVEMENT

**CONCRETE PAVEMENT
REPAIR AND REPLACEMENT**

STATE OF WISCONSIN
DEPARTMENT OF TRANSPORTATION

GENERAL NOTES

- ① WITH THE APPROVAL OF THE ENGINEER, FOR SINGLE LANE PAVEMENT REPLACEMENTS LESS THAN 30 FEET IN LENGTH, THE CONTRACTOR MAY INSTALL DRILLED TIE BARS ON 6:1 SKEW HORIZONTALLY, DIRECTION OF SKEW ALTERNATING WITH EACH SUCCESSIVE BAR. DRIVE SKEWED TIE BARS TO A DEPTH OF 6 INCHES AND TO SUCH A DIAMETER AS TO PROVIDE A TIGHT DRIVEN FIT.
- ② USE AN ENGINEER-APPROVED BOND BREAKER FOR SINGLE LANE REPAIRS UP TO 15 FEET IN LENGTH.

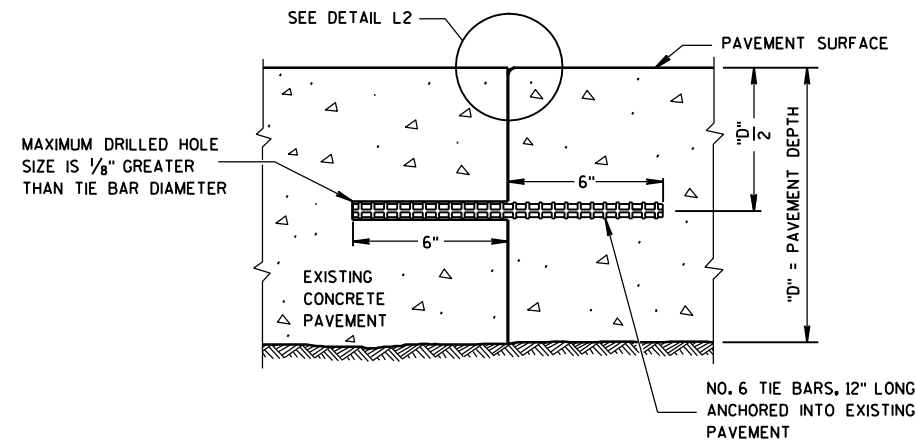

SECTION G-G
**TIE BARS ANCHORED
 INTO EXISTING PAVEMENT**

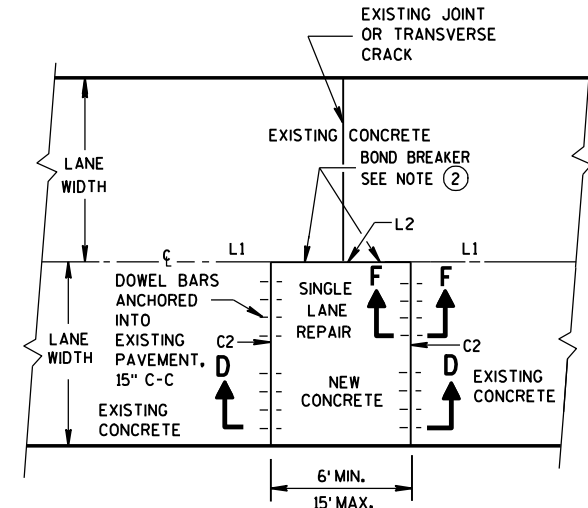

PLAN VIEW
**SINGLE LANE
 CONCRETE PAVEMENT REPAIR**

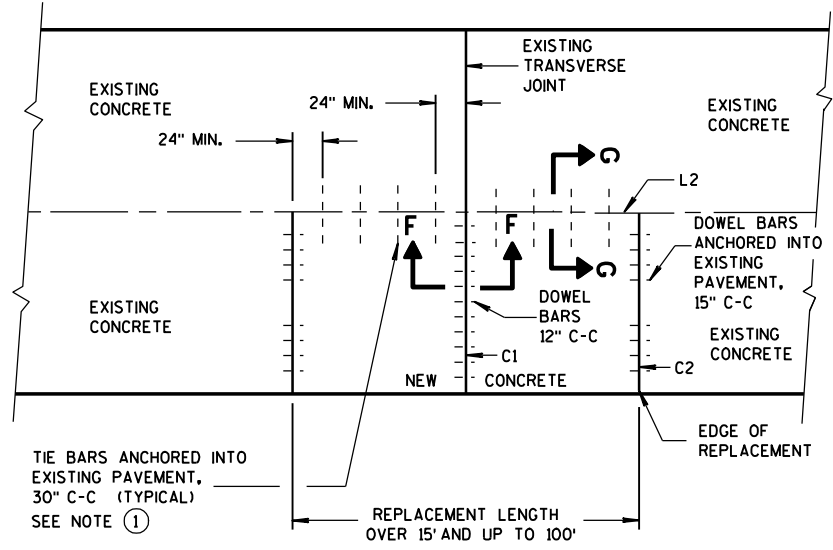

PLAN VIEW
**SINGLE LANE
 CONCRETE PAVEMENT REPLACEMENT**

CONCRETE PAVEMENT REPAIR AND REPLACEMENT	
STATE OF WISCONSIN DEPARTMENT OF TRANSPORTATION	
APPROVED 12-11-09 DATE	/S/ Deb Bischoff PAVEMENT POLICY & DESIGN ENGINEER
FHWA	

Standard Detail Drawing 13C9-8(a-c)

References:

[FDM 14-25-10](#)

Bid items associated with this drawing:

<u>ITEM NUMBER</u>	<u>DESCRIPTION</u>	<u>UNIT</u>
204.0100	Removing Pavement.....	SY
415.0060 - 415.0199	Concrete Pavement (inch)	SY
415.1080 -415.1199	Concrete Pavement HES (inch).....	SY
416.0610	Drilled Tie Bars	EACH
416.0620	Drilled Dowel Bars	EACH
416.0905	Concrete Pavement Continuous Diamond Grinding.....	SY
416.1710	Concrete Pavement Repair	SY
416.1715	Concrete Pavement Repair SHES.....	SY
416.1720	Concrete Pavement Replacement.....	SY
416.1725	Concrete Pavement Replacement SHES	SY
690.0250	Sawing Concrete.....	LF

Standardized Special Provisions associated with this drawing:

<u>STSP NUMBER</u>	<u>TITLE</u>
NONE	

Other SDDs associated with this drawing:

13C11
13C13

Design Notes:

Always include SDDs 13C9a, b & c together in plan sets.

If Concrete Pavement Repair or Concrete Pavement Repair SHES are part of a project, designers should also consider including Concrete Pavement Replacement or Concrete Pavement Replacement SHES and Concrete Pavement (inch) or Concrete Pavement HES (inch) bid items since unforeseen pavement repairs may extend beyond 15 feet in length.

Contact Person:

Deb Bischoff: (608) 246-7957